

**SMP3316** TRADITIONAL Pb  
**SMP3316LF\*** ROHS COMPLIANT

Molded Unshielded Inductor

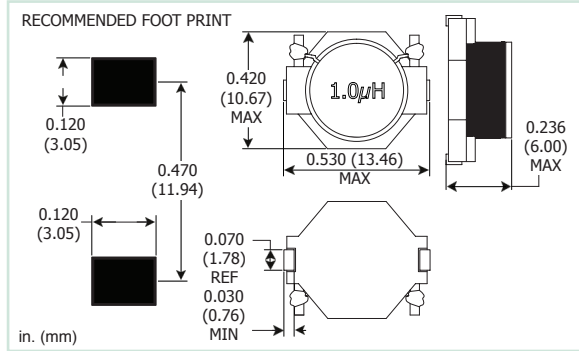

PART NUMBER	L $\mu$ H @ 100 kHz	DCR $\Omega$ MAX	I SAT A DC	CURRENT RATING A DC
<b>FERRITE CORE</b>				
SMP3316-101M	1.0	0.0065	11.0	9.3
SMP3316-151M	1.5	0.0080	10.4	8.3
SMP3316-221M	2.2	0.0090	7.8	7.6
SMP3316-331M	3.3	0.0128	7.0	6.5
SMP3316-471M	4.7	0.0160	5.6	5.6
SMP3316-681M	6.8	0.0202	5.0	5.0
SMP3316-102M	10	0.0267	4.2	4.4
SMP3316-152M	15	0.0410	3.4	3.5
SMP3316-222M	22	0.0600	3.0	2.9
SMP3316-332M	33	0.0917	2.4	2.3
SMP3316-472M	47	0.1300	1.8	2.0
SMP3316-682M	68	0.1780	1.6	1.7
SMP3316-103M	100	0.2600	1.4	1.4
SMP3316-153M	150	0.3800	1.0	1.2
SMP3316-223M	220	0.5500	0.90	0.97
SMP3316-333M	330	0.8700	0.70	0.77
SMP3316-473M	470	1.23	0.64	0.65
SMP3316-683M	680	1.71	0.50	0.55
SMP3316-104M	1000	2.64	0.42	0.44

**NOTES:**

- **Operating Temperature Range:** -55°C to +125°C
- **Current Rating** is based on a 40°C temperature rise at an ambient temperature of 85°C
- **Saturation Current** is the approximate value that will reduce the initial inductance by 10%
- **Weight Max:** 1.25 grams
- **Marking:** Inductance  
1.0 $\mu$ H
- Molded Epoxy base for superior heat strength
- Can be used for all types of power applications including filters for DC/DC convertres and switching regulated power supplies
- When ordering, specify **tolerance & termination:**  
SMP3316-101MLF  
**Tolerance:** M = 20%  
(Table shows lowest standard tolerance option)  
\*Optional tolerances are available; contact factory  
**Termination:** LF = RoHS compliant tin-silver copper over copper
- Custom designs are available to meet your specific requirements; please contact factory

**TAPE AND REEL SPECS:**

Pcs./Reel maximum:	700
Pitch between parts:	16 mm
Tape width:	24 mm
Reel diameter:	13 in.